

## REACTIVE POWER PLANNING IN DISTRIBUTION SYSTEM USING GENETIC ALGORITHM

### تخطيط القدرة الغير فعالة في شبكة التوزيع باستخدام خوارزم جيني

G. E. M. Aly  
Faculty of Engineering,  
Tanta University

H. El-Desouki      Amany El-Zonkoly  
Arab Academy for Science & Technology,  
Alex., Egypt

#### ملخص:

في هذا البحث يتم عرض حل لمشكلة التحكم في القدرة الغير فعالة و الجهد في شبكة التوزيع باستخدام خوارزم جيني. تم تقسيم الحل في هذه المشكلة الى جزئين. في الجزء الأول يتم تحديد الأماكن المرشحة لوضع مصادر القدرة الغير فعالة عندها. اما في الجزء الثاني او المرحلة الثانية من الحل يتم تحديد الأماكن الفعلية لتوصيل مصادر القدرة الغير فعالة كما يتم تحديد العدد و الحجم الأمثل لهذه المصادر. تم تطبيق هذه الطريقة في الحل على نظام اختبار IEEE 12-bus.

#### Abstract:

This paper presents a solution for the Volt/VAR control (VVC) problem in distribution system using Genetic Algorithm (GA). The problem is divided into two parts. In the first part the candidate buses for reactive power insertion are determined. In the second part the locations, number and sizes of reactive power sources are determined in an optimal manner. The solution method has been implemented and tested with a 12-bus IEEE test system.

**Key Words:** Volt/VAR control – Distribution System – Genetic Algorithm.

#### 1. Introduction:

The underlying power system control function is to provide every single consumer an electricity supply within tight bounds of frequency and voltage level while allowing them to switch appliances at any time. The reactive power injection is the most fundamental method for voltage control. Capacitors are widely used in distribution systems to achieve power and energy loss reduction and to maintain a voltage profile within permissible limits [1]. Capacitors are used during heavy loads where the voltage drop is high and

voltage magnitude is low to raise it back within its limits. When the voltage rises during light loads, reactors are used to lower it back within its limits. The problem is to choose the optimum allocation and value of the reactive power sources to minimize the summation of the cost of system power loss and the cost of reactive power sources while satisfying the operational constraints at different load levels.

To find the optimal solution of the above formulated problem, the genetic algorithms are used. Genetic algorithms imitate the process of natural evolution. GA based solution as presented in this paper is capable of determining a near global optimum solution with a reasonable computational burden.

On a theoretical bases, simulated annealing (SA) [2] has the capability to search a near optimum global solution but the computational burden is heavy in arriving at such a solution. Application of GA in the reactive power planning firstly introduced by K. Iba [3], the objective function was formulated to include the power loss, weighted voltage violations and weighted generator VAR violations. Sensitivity based heuristic has been used in [4,5], although it tends to reduce the number of locations for capacitors in distribution system but it costs more time, several hours, to find the optimum solution.

In this paper, GA has been successfully applied to the Volt/VAR control problem in distribution system. The design variables are the reactive power sources sizes at the candidate buses. The fitness value for each string is the reciprocal of the objective function, which is the summation of the cost of real power loss and the cost of reactive power sources placement.

## **2. Problem Formulation:**

From a mathematical standpoint, the VVC optimization problem is a minimization problem with equality and inequality constraints. The value of the objective function is determined from the power flow solution given the settings of the control variables. The goal is to find the minimum value of the objective function, while satisfying the constraints and limits [6].

The VVC problem is the determination of the location, number and sizes of capacitors/reactors to be placed on a distribution system in an optimal manner. The objective is to minimize the total cost of the selected placement scheme. The total cost consists of the cost of placements and the cost of real power loss and can be expressed as follows:

$$\text{Min } f(x,u) = \text{cost of placements} + \text{cost of real power loss}$$

where  $f(x,u)$  is the cost function or objective function. The state variable  $x$  represents the state of the distribution system and the placement scheme is represented by the variable  $u$  [5].

The power flow equations are used to represent the equality constraints for this problem. They are expressed as follows:

$$P_{gi} - P_{di} = \sum |V_i| |V_j| |Y_{ij}| \cos(\theta_{ij} - \delta_i + \delta_j) \quad \text{for all buses } i=1, \dots, \text{nbus}$$

$$Q_{gi} - Q_{di} = - \sum |V_i| |V_j| |Y_{ij}| \sin(\theta_{ij} - \delta_i + \delta_j) \quad \text{for PV buses } i=1, \dots, \text{ngen}$$

$$Q_{gi} - Q_{di} + Q_{si} = - \sum |V_i| |V_j| |Y_{ij}| \sin(\theta_{ij} - \delta_i + \delta_j) \quad \text{for PQ buses } i=1, \dots, \text{nload}$$

Where,  $P_{gi}$ ,  $Q_{gi}$ : real and reactive power generation at bus  $i$ , respectively.

$P_{di}$ ,  $Q_{di}$ : real and reactive power demand at bus  $i$ , respectively.

$Q_{si}$ : reactive power support from reactive power source at bus  $i$ .

$Y_{ij}, \theta_{ij}$ : magnitude and angle of an element of network admittance matrix.

$V_i, \delta_i$ : magnitude and angle of the voltage at bus  $i$ .

The inequality constraints for optimal placement are the quality of service considerations and equipment limitations utility companies experience such as the voltage magnitude. The voltage magnitude constraint could be expressed as follows:

$$|V_{\min}| \leq |V_i| \leq |V_{\max}| \quad \text{for all buses } i=1, \dots, \text{nbus.}$$

$$Q_{gi}^{\min} \leq Q_{gi} \leq Q_{gi}^{\max} \quad \text{for PV buses } i=1, \dots, \text{ngen.}$$

$|V_{\min}|$  and  $|V_{\max}|$  are the specified acceptable voltage magnitude limits and  $Q_{gi}^{\min}$  and  $Q_{gi}^{\max}$  are the reactive power generation limits.

### **3. Genetic Algorithms:**

Genetic algorithms are inspired by the mechanism of natural selection, a biological process in which stronger individuals are likely to be the winners in a competitive environment. They presume that the potential solution of problem is an individual and can be represented by a set of parameters. These parameters are regarded as the genes of a chromosome and can be structured by a string of values in binary form. A positive value, generally known as fitness value, is used to reflect the degree of "goodness" of the chromosome for solving the problem [7].

If a population of strings  $P(t)$ , during a generation  $t$  is considered, a simple GA can be implemented as follows [8]:

*Procedure GA*

*begin*

*t=0;*

*initialize P(t);*

*evaluate strings in P(t);*

*while termination condition not satisfied do*

*begin*

*t=t+1;*

*select P(t) from P(t-1);*

*recombine structures in P(t);*

*evaluate structures in P(t);*

*end*

*end*

The algorithm starts from an initial population generated randomly. Using the genetic operations considering the fitness of a solution, which corresponds to the objective function for the problem generates a new generation is generated. The fitnesses of solutions are improved through iterations of generations. When the algorithm converges, a group of solutions with better fitnesses is generated, and the optimal solution is obtained [9,10].

The main components of GAs are:

1. Coding: representing the problem at hand by strings.
2. Initialization: initializing the strings.
3. Fitness Evaluation: determining how fit is a string.
4. Selection: deciding who mates.
5. Crossover: exchanging information between two mates.
6. Mutation: introducing random information.

1. *Coding:*

Each individual in the population consists of a number of parameters equal to the number of weak buses with relatively high VCPI. Each parameter is binary coded to form the chromosome. The value of each parameter expresses the size of VAR source placed at the selected bus.

2. *Initialization:*

Fair coin tosses are used to initialize all binary coded strings forming the unrated population.

3. *Fitness Evaluation:*

All strings are evaluated with the same fitness function. The fitness function incorporates the objective function, i.e., the total cost of the proposed capacitor placement scheme with the cost of real power loss and cost penalties if a string violates any of the constraints. In this way a rated population is formed and GA proceeds such that the fitness function is maximized and, consequently, the objective function is minimized.

4. *Selection:*

The roulette-wheel selection scheme is used. Each slot on the wheel is paired with an individual in the population. The size of each slot is proportional to the corresponding individual fitness. In such a scheme, a fitter string receives a higher number of offspring and thus has a higher chance of surviving in the subsequent generation.

5. *Crossover:*

Given a crossover probability, simple crossover is performed to exchange information between strings. In the proposed algorithm single-point crossover is performed.

6. *Mutation:*

Given a mutation probability, random alteration of genes in a string may occur. For a binary coded string, a mutation represents a simple bit change.

7. *Convergence / Termination of the GA:*

When the maximum allowable number of generations for the GA is reached the best solution found so far is returned.

Figure (1) shows a complete cycle representing one generation of the search: [11]

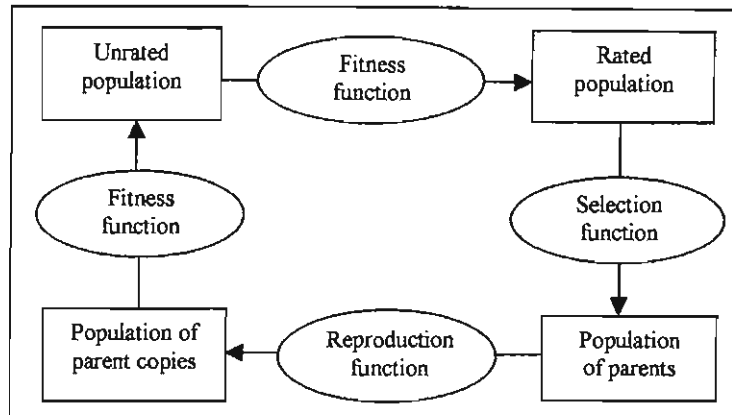

Figure (1): General procedure for all evolutionary computations.

#### **4. Problem Solution:**

##### a. Conventional Analytical Optimization Method:

In this method the solution proceed as follows. Firstly, the original network is analyzed without any shunt compensation then the nodes with voltage magnitudes out of limits are considered as candidate buses for compensators placements. The next step now is to find the optimum capacitor sizing to be placed at the predetermined sites. Finding the optimum value for these capacitor banks involve a basic iterative technique to "home in" on the optimum value within a tolerance. A series of power flow analysis are performed to test whether the voltage profile is within tolerance. If the profile is within tolerance, the capacitance is decreased. If the profile is outside the tolerance, it is increased. The initial capacitor value to be placed at the candidate node will be equal to the total reactive power at such node [13]. Capacitors are applied when the nodes exhibit under-voltages, while reactors are applied when the nodes exhibit over-voltages.

##### b. Genetic Algorithm Method:

The problem solution methodology is simple and straight forward and summarized as follows:

Part I: Determination of candidate locations for capacitor/reactor siting:

1. Input the distribution system branch impedance values and the bus real and reactive power data.
2. Form the admittance matrix.
3. Perform the power flow calculations to determine the bus voltage magnitudes.
4. Select the buses with voltage magnitudes out of limit as candidate buses.

**Part II:** Determination of optimal size, location and number of reactive power sources:

The purpose of GA is to determine the reactive power source size at the candidate locations during 24 hours loading. If we have  $n$  candidate locations, the GA returns the value of  $n$  design variables.

The algorithm is as follows:

1. Form an initial population of  $K$  strings each representing  $n$  variable.
2. Evaluate the fitness value for each string, i.e. evaluate the reciprocal of the objective function value.
3. Strings with higher fitness values are selected for reproduction and crossover.
4. Repeat step 3 until maximum number of generation is reached.

### **5. Numerical Results:**

The proposed method was implemented and tested with an 12-bus IEEE test system shown in figure (2) [12].

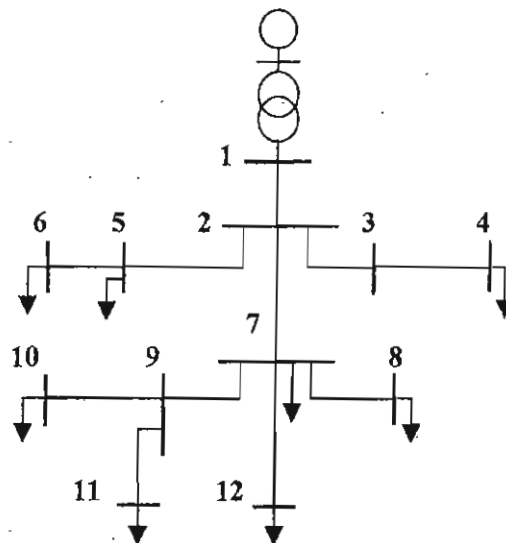

**Figure (2): IEEE 12 – Bus System**

The test parameters were chosen as follows:

Population size = 20

Maximum generation = 20

Crossover probability = 0.9

Mutation probability = 0.001

Real power cost = 60 \$/MWh

Capacitor cost = 3800 \$/MVAR

Reactor cost = 5500 \$/MVAR [13]

The voltage magnitude limits: 0.95 – 1.05 pu

Table 1 summarizes the test results.

Table 1 summarizes the test results.

**Table 1: Comparison between the results before and after compensation:**

Bus No.	Voltage Magnitudes (pu)					
	Before Compensation		After Compensation Using Conventional Method		After Compensation Using GA Method	
	Max.	Min.	Max.	Min.	Max.	Min.
1	1.06	1.06	1.06	1.06	1.06	1.06
2	1.052	1.032	1.041	1.001	1.048	1.033
3	1.052	1.032	1.041	0.993	1.048	1.033
4	1.05	1.029	1.038	0.956	1.046	1.03
5	1.05	1.026	1.036	0.99	1.046	1.027
6	1.05	1.024	1.034	0.99	1.045	1.025
7	1.047	1.01	1.028	0.995	1.042	1.012
8	1.021	0.948	0.971	0.96	1.016	0.951
9	1.046	1.007	1.026	0.995	1.042	1.009
10	1.046	1.006	1.025	0.994	1.042	1.008
11	1.046	1.006	1.024	0.994	1.042	1.008
12	1.047	1.01	1.028	0.995	1.042	1.012
Total Loss (MW)	2.442		3.0774		2.4279	
Total Cost (\$)	-----		35197.1142		2365.703	

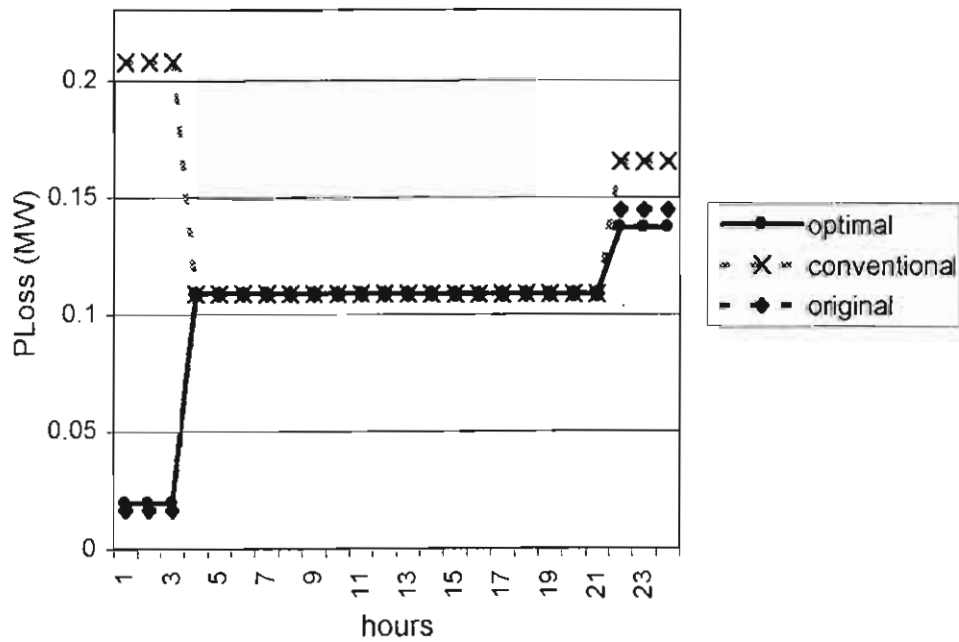

**Figure (3): Power Loss During 24 hours**

light loading and bus 8 with lower limit violation during heavy loading. To compensate such violations two ways were applied, conventional and GA methods. The conventional method resulted in the insertion of reactors of rating 0.448 MVAR at buses 2,3 and 4, and a reactor of rating 0.427 at bus 5 during hours of light loading. During hours of heavy loading a capacitor of rating 0.51 MVAR was placed at bus 8. The GA method resulted in a reactor of rating 0.1 MVAR placed at bus 2 during the hours of light loading, while a capacitor of rating 0.05 MVAR was placed at bus 8 during the hours of heavy loading. It is also shown from table 1 that the total real power loss during the 24 hours was reduced using the GA method while it was increased using the conventional method. From figure (3), it is shown that the power loss resulted from using GA method was raised in the first 3 hours due to the insertion of the reactor at bus 2 and was reduced during the last 3 hours of the day due to capacitor insertion at bus 8. But as mentioned before the total power loss during the day was reduced. It is also shown that the real power loss resulted from using the conventional method is higher than that of the real power loss of the system before compensation or the one resulted from using the GA method.

### **6. Conclusion:**

In this paper, a solution framework for solving the Volt/VAR control problem in distribution system using genetic algorithms has been presented. The problem is to determine the locations, number and sizes of capacitors/reactors to be placed in a distribution system in an optimum manner. The solution method can provide a near global optimum solution to the VVC problem. The solution method has been implemented and tested with an IEEE 12-bus system. As a result of that the voltage profile was improved and its violations disappeared. Also, the total real power loss of the system was reduced.

Genetic algorithms are well suited for problems, which are combinatorial in nature. They are capable of handling both continuous and discrete variables efficiently without any change in the search mechanism. GAs are slower than traditional optimization algorithms but they have the ability to be processed in parallel. This implicit parallelism makes them the most suitable for design optimization in a parallel computing environment.

### **References:**

- [1] G.Levitin, A.Kalyuzhny, A.Shenkman and M.Chertkov," Optimal Capacitor Allocation in Distribution Systems Using a Genetic Algorithm and a Fast Energy Loss Computation Technique", IEEE Trans. Power Systems, Vol. 15, No. 2, April 2000, pp 623-628.
- [2] H.D.Chiang, J.C.Wang, J.T.Tong and G.Darling," Optimal Capacitor Placement, Replacement and Control in Large-Scale Unbalanced Distribution Systems: System Modeling and a New formulation.", IEEE Trans. on Power Systems, Vol.1, No.1, Feb 95, pp. 356-362.



- [3] K.Iba, "Reactive Power optimization by Genetic Algorithm", IEEE Trans. on Power Systems, Vol.9, No.2, May 94, pp.685-692.
- [4] S.Sundharajan and A.Pahwa, "Optimal Selection of Capacitor for Radial Distribution System Using Genetic Algorithms", IEEE Trans. Power Systems, Vol.9, No. 3, Aug. 94, pp. 1499-1507.
- [5] K.N.Miu, H.D.Chiang and G.Darling, "Capacitor Placement, Replacement and Control in Large-Scale Distribution Systems by a GA-Based Two-Stage Algorithm", IEEE Trans. Power Systems, Vol.12, No.3, Aug 97, pp. 1160-1166.
- [6] I.Roytelman, B.K.We e and R.L.Lugtu, "Volt/VAR Control Algorithm for Modern Distribution Management System", IEEE Trans. Power Systems, Vol.10, No.3, Aug 95, pp. 1454-1460.
- [7] V. Miranda, J.V. Ranito, and L.M. Proenca, "Genetic algorithm in optimal multistage distribution network planning", IEEE PES Winter Meeting, #94 WM 229-5-PWRS.
- [8] J.J.Grefenstette, "Optimization of Control parameters for Genetic Algorithms", IEEE Trans. Systems, Man and Cyb., Vol.SMC-16, Jan/Feb. 1986, pp 122-128.
- [9] K. Iba, "Reactive Power Optimization by Genetic Algorithm", IEEE Trans. Power Systems, Vol. 9, No. 2, May 1994, pp. 685-692.
- [10] D.E. Goldberg, *Genetic Algorithms in Search, Optimization, and Machine Learning*, Addison Wesley, 1989.
- [11] Kwang Y. Lee, Xiaomin Bai, Young-Moon Park, "Optimization Method for Reactive Power Planning by Using a Modified Simple Genetic Algorithm", IEEE Trans. Power Systems, Vol. 10, No.4, Nov.1995, pp 1843-1850.
- [12] IEEE Distribution Planning Working Group Report, "Radial Distribution Test Feeders", IEEE Trans. Power Systems, Vol. 6, No. 3, Aug 91, pp. 975-985.
- [13] E.Bartlett and M.M.Elkatheb, "An Investigation into Power Flow Analysis Techniques & Optimization of Capacitor Shunt Compensation for Radial Distribution Systems", MEPCON'98, pp.37-41.