

"EFFECTS OF HOLE INCLINATION ON THE FILM
COOLING TECHNIQUES"

BY

S. F. HANNA, M. M. AWAD, N. S. MATTA ^{■)}

A B S T R A C T

This paper presents an experimental investigation on the injection characteristics of a single hole at the leading edge of a flat plate immersed in mainstream air.

The influence of the hole diameter, hole inclination angle, and pressure difference coefficients on the flow rate coefficient of an injection hole is investigated.

For designing film cooled blades, it is necessary to predict the characteristics of the coolant flow rate from each injection hole. It is found that the maximum flow rate coefficient occurs at a hole inclination angle of 35° for different hole diameter and different pressure coefficient. Flow rate coefficient increases with increasing pressure coefficient.

NOMENCLATURE:

| | | |
|-------------|----------------------------------|--|
| A | Cross sectional area of the hole | cm^2 |
| c_{p2} | Secondary pressure coefficient | $= (p_2 - p_\infty) / \frac{1}{2} \rho u_\infty^2$ |
| c_{pe} | " | " with zero injection rate |
| d | Hole diameter | cm |
| p | Pressure | N/cm^2 |
| t | Temperature | $^\circ\text{C}$ |
| \dot{V}_2 | Coolant flow rate | m^3/sec |
| Re | Reynolds number | $= \frac{u_\infty d}{\nu}$ |
| u_∞ | Free stream velocity | m/sec |

■) Faculty Of Engineering, Mechanical Engineering Dept.
Mansoura University

M.2. HANNA, AWAD & MATTA

| | |
|----------|---|
| u_2 | Injection velocity (secondary air velocity) m/s |
| α | Flow rate coefficient dimensionless |
| β | Injection angle degree |
| ρ | Density kg/m^3 |
| η | Dimensionless ratio, Film heating (cooling) effectiveness; $(T_{w2} - T_{\infty}) / (T_2 - T_{\infty})$ |

INDICES:

| | |
|----------|--------------------------|
| 2 | Secondary (coolant) flow |
| e | Zero injection rate |
| ∞ | Free stream |

1. INTRODUCTION

The remarkable increase of turbine inlet temperature in modern gas turbine engines has been achieved not only by the development of high-temperature materials but also by the improvement of cooling structure of turbine blades. The protection of flat and circumferential surfaces have studied^{1, 2}. Many kinds of convection-cooled turbine blades have been developed during the past few years³, and recently hollow-structure blades adopting both convection and film cooling have appeared. These blades are not only cooled from the inside by convection and impingement of cooling air introduced through passages in their roots and tip portions, but also shielded from outer hot gases with a film of cooling air injected through holes on their surfaces.

For designing film cooled blades, it is necessary to predict the characteristics of the coolant flow rate from each injection hole.

In this paper an experimental study is performed on injection characteristics from a single hole on a flat plate immersed in a stream parallel to the plate surface. Effects of the diameter and the angle of hole inclination on the injection characteristics and the effectiveness of the film cooling are investigated.

2. DESCRIPTION OF TEST METHODOLOGY AND EQUIPMENTS

The test rig and the plate model are constructed as shown in Fig.(1). All pertinent symbols are defined on this figure. The coolant flow rate coefficient for round holes located near the leading edge for a flat plate is considered. The injectors have different diameter holes inclined at different angles. The angles are 20, 35, 50, 65, and 90 degree inclined against the flat plate surface in order to facilitate investigation of flow rate characteristics of the inclined injection holes near the leading edge that can make good film formation of coolant.

The model was set at the center of the test section of an open wind tunnel with its axis parallel to the main flow direction. The model width is 300 mm., and the injector is located at the center of the model width near the leading edge. The geometry of the hole is changed by changing the injector for different angles. The secondary air was supplied from a blower through a control valve and an orifice. The main air flow was at ambient temperature and its velocity u_{∞} for these experiments was about 17 m/sec and the temperature of secondary air was equal to 50 °C.

3. TEST RESULTS

3.1 Injection Flow Rate Coefficient

For injection test, results of the flow rate coefficient α^* is defined as follows:

The flow rate q_2 is expressed

$$q_2 = a \cdot u_2 = a \cdot \alpha \cdot \sqrt{2(p_2 - p_e) / \rho_2} \quad \dots\dots (1)$$

Dividing Eq.(1) by the main flow dynamic pressure (when a main flow exists), Eq.(1) yields

$$\frac{A \cdot u_2}{\frac{1}{2} \rho_{\infty} u_{\infty}^2} = \sqrt{\frac{2 \cdot A \cdot \alpha}{\rho_2 \rho_{\infty} u_{\infty}^2}} \sqrt{\frac{p_2 - p_e}{\frac{1}{2} \rho_{\infty} u_{\infty}^2}}$$



Part B



Part A

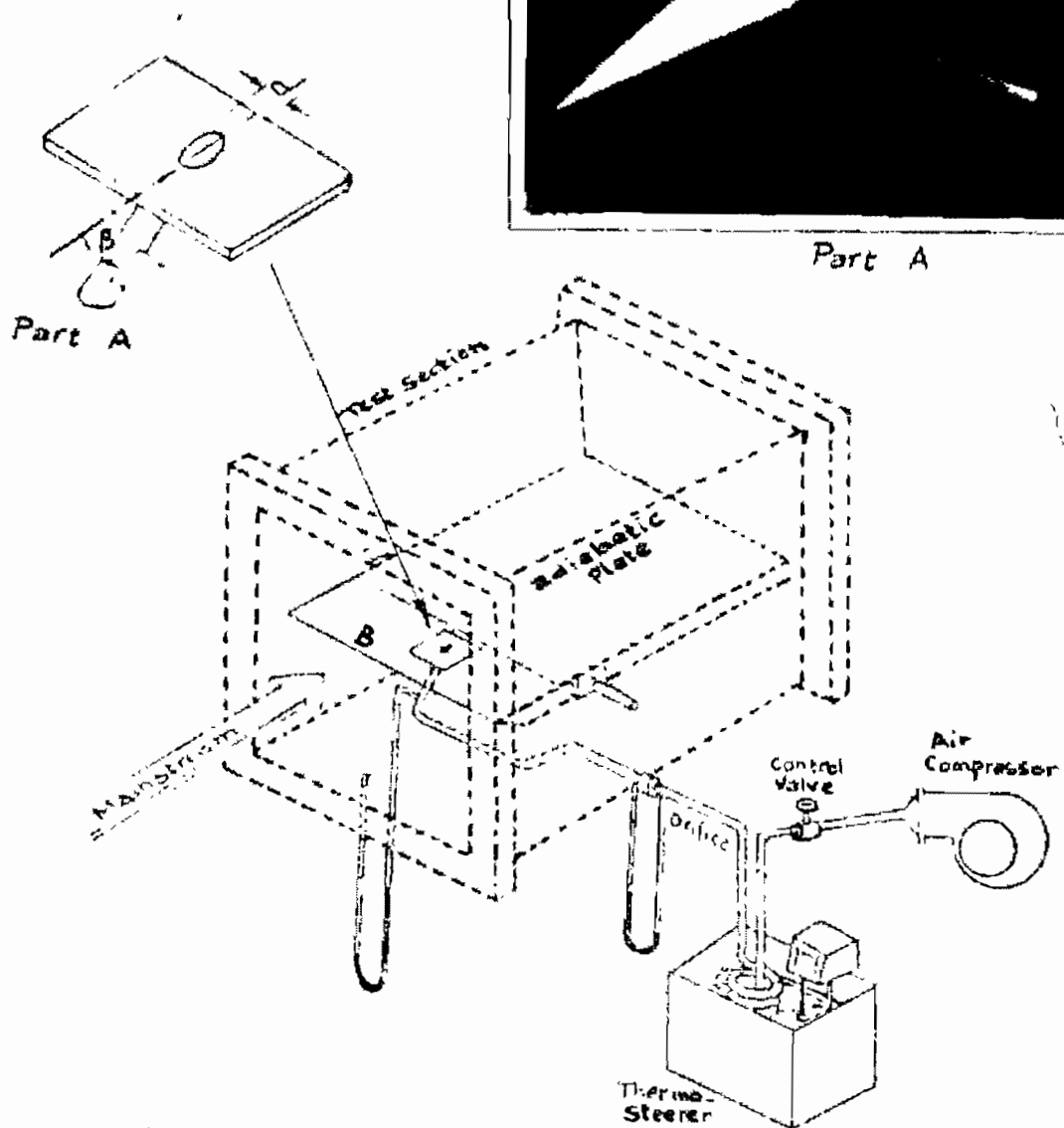

Fig. (1) Test Rig

or

$$\frac{u_2}{u_\infty} \sqrt{\rho_2/\rho_\infty} = \alpha \sqrt{(c_{p2} - c_{pe})} \quad (2)$$

where:

$$c_{p2} = (p_2 - p_\infty) / \frac{1}{2} \rho_\infty u_\infty^2,$$

$$c_{pe} = (p_e - p_\infty) / \frac{1}{2} \rho_\infty u_\infty^2$$

Figure (2) shows the flow rate coefficient (α) which is defined by Eq.(2). These results indicate that the coefficients are largely variable with the pressure-coefficient differences ($c_{p2} - c_{pe}$). The tendency of a change in the coefficient (α) is nearly similar to each other. Decreasing the injection angle (toward tangential injection), the level of the flow rate increases. Maximum flow rate coefficient (α) occurs nearly at a hole inclination angle of 35 deg to the main stream direction. The flow rate coefficient is more sensitive to the pressure-coefficient difference in the case of holes with larger diameter than that with smaller one. The flow rate coefficient (α) depends on the hole diameter, the hole angle of inclination and the pressure difference coefficients ($c_{p2} - c_{pe}$) as mentioned above.

The flow rate coefficient (α) is drawn versus the inclination angle of the injection hole (β). This relation is given in Fig.(3) for two values of ($c_{p2} - c_{pe} = 0.5$ & 1.0) and different hole diameters $d = 3$ & 6 mm. One may conclude from the figure that, the maximum injection flow rate characteristics has a larger value for the injection through hole with a large diameter than that with a smaller one. The injection flow rate characteristics have a peak value at about 35° angle of inclination for holes of different diameters.

3.2 Film Cooling Effectiveness

The film cooling effectiveness is determined from the following relation:

$$\eta = (T_{w2} - T_\infty) / (T_2 - T_\infty)$$

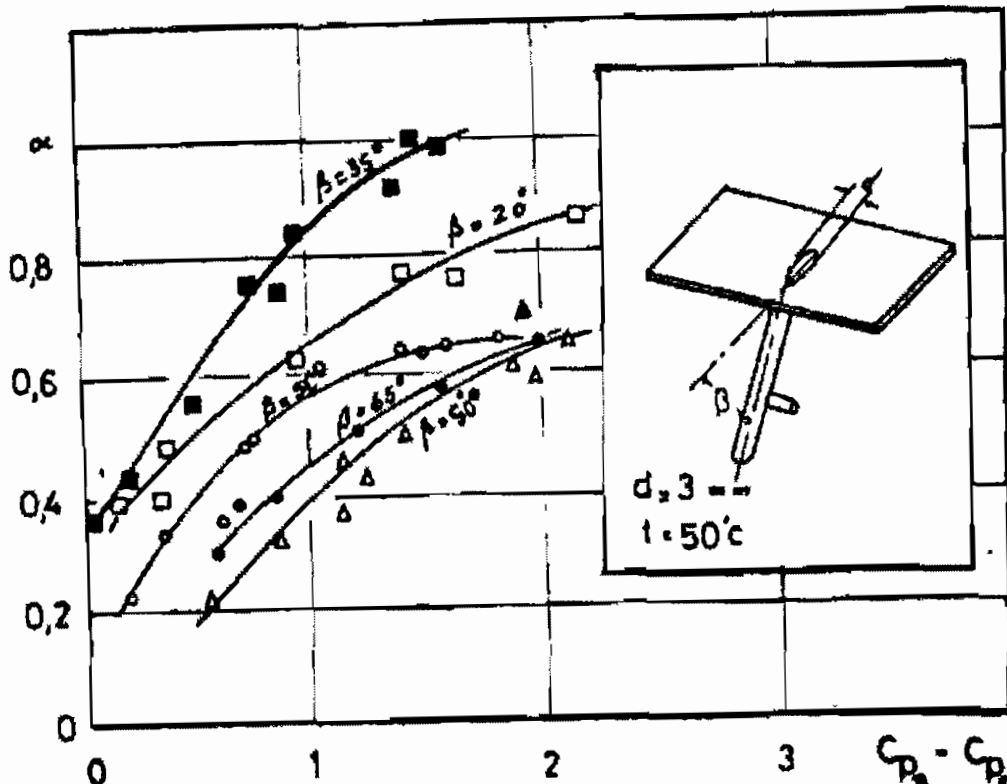
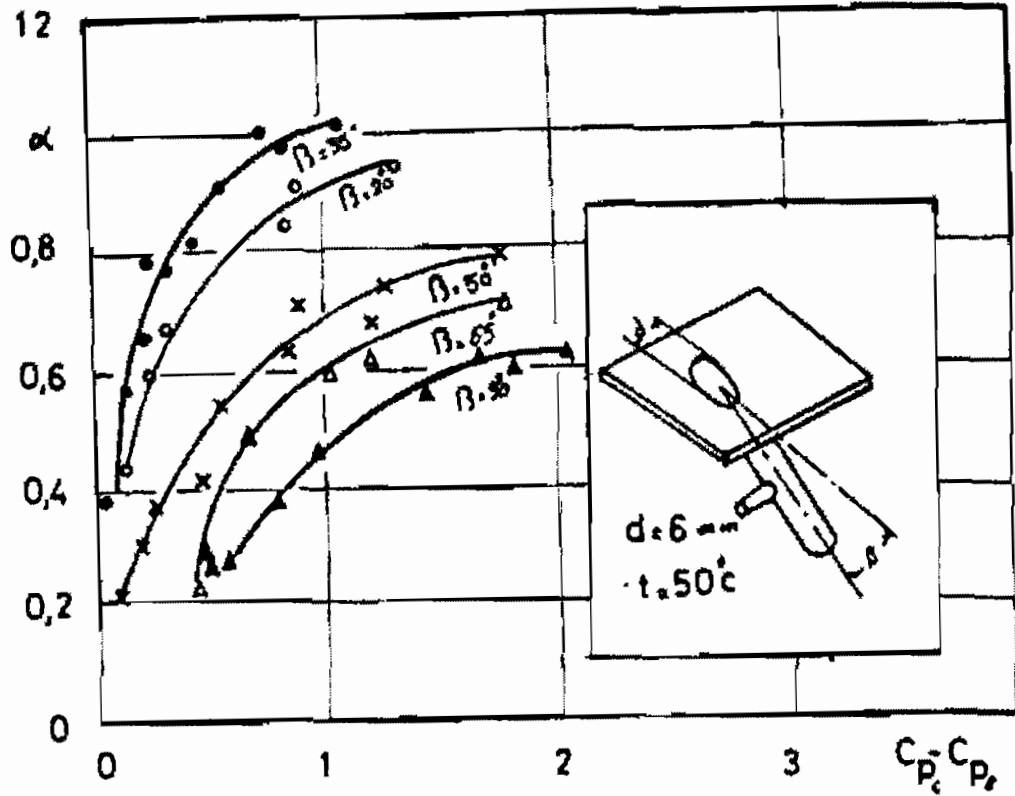

Fig.2 Flow Rate Coefficient For Hole Diameter $d = 3 \text{ \& } 6 \text{ mm}$

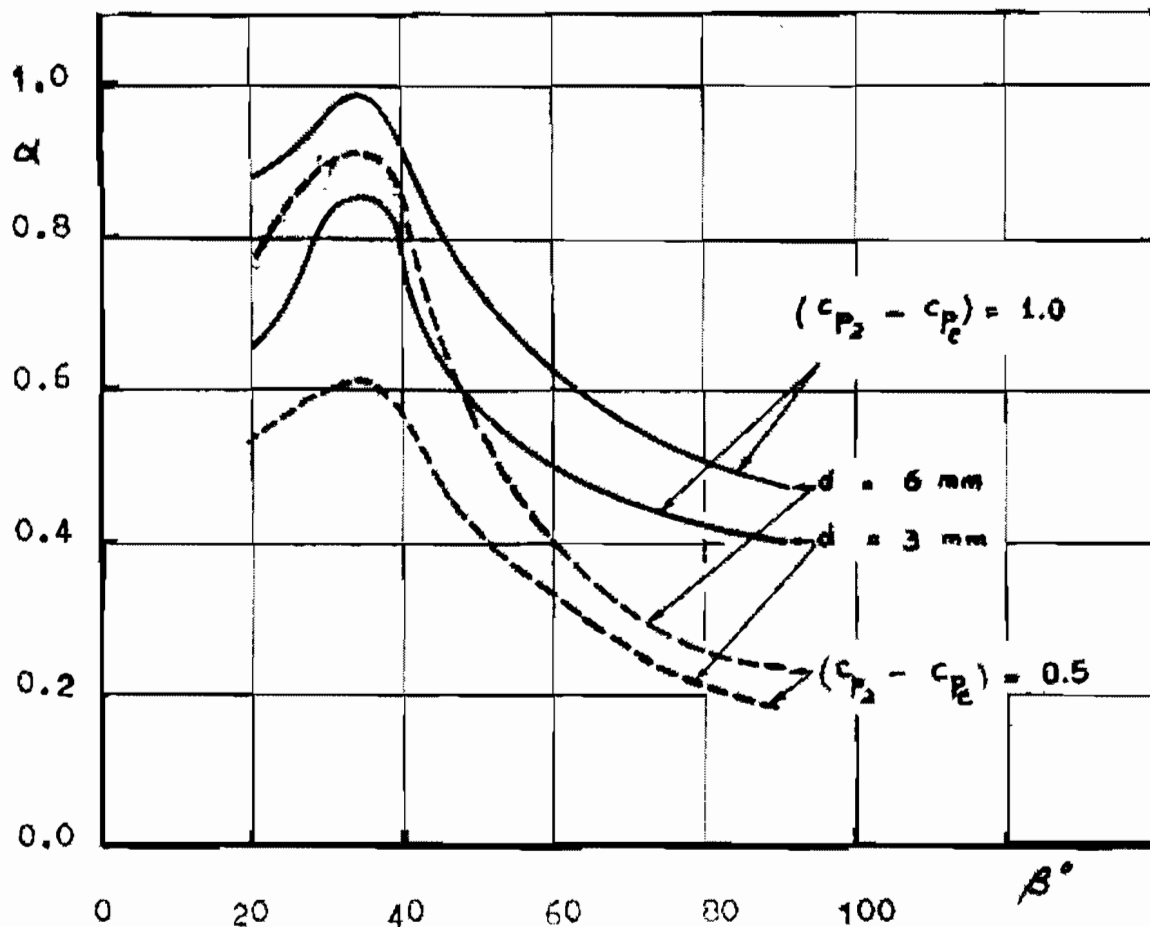

Fig.(3) Flow Rate Coefficient Versus Injection Angle

Fig.(4) shows the film cooling effectiveness for the case of the optimum inclination of the injection hole ($\beta = 35^\circ$) to the plate angle. It is clear that the maximum value of the effectiveness decreases along the distance far from the injection hole.

CONCLUSIONS

The principal conclusions of the study are summarized as follows:

- 1- An experimental procedure has been described which predict the injection characteristics of a single hole at the leading edge of a flat plate immersed in mainstream air.
- 2- The hole diameter, hole inclination angle, and pressure-difference coefficient has an influence on the flow rate coefficient. Moreover, the maximum flow rate coefficient occurs at a hole inclination angle of 35° for different

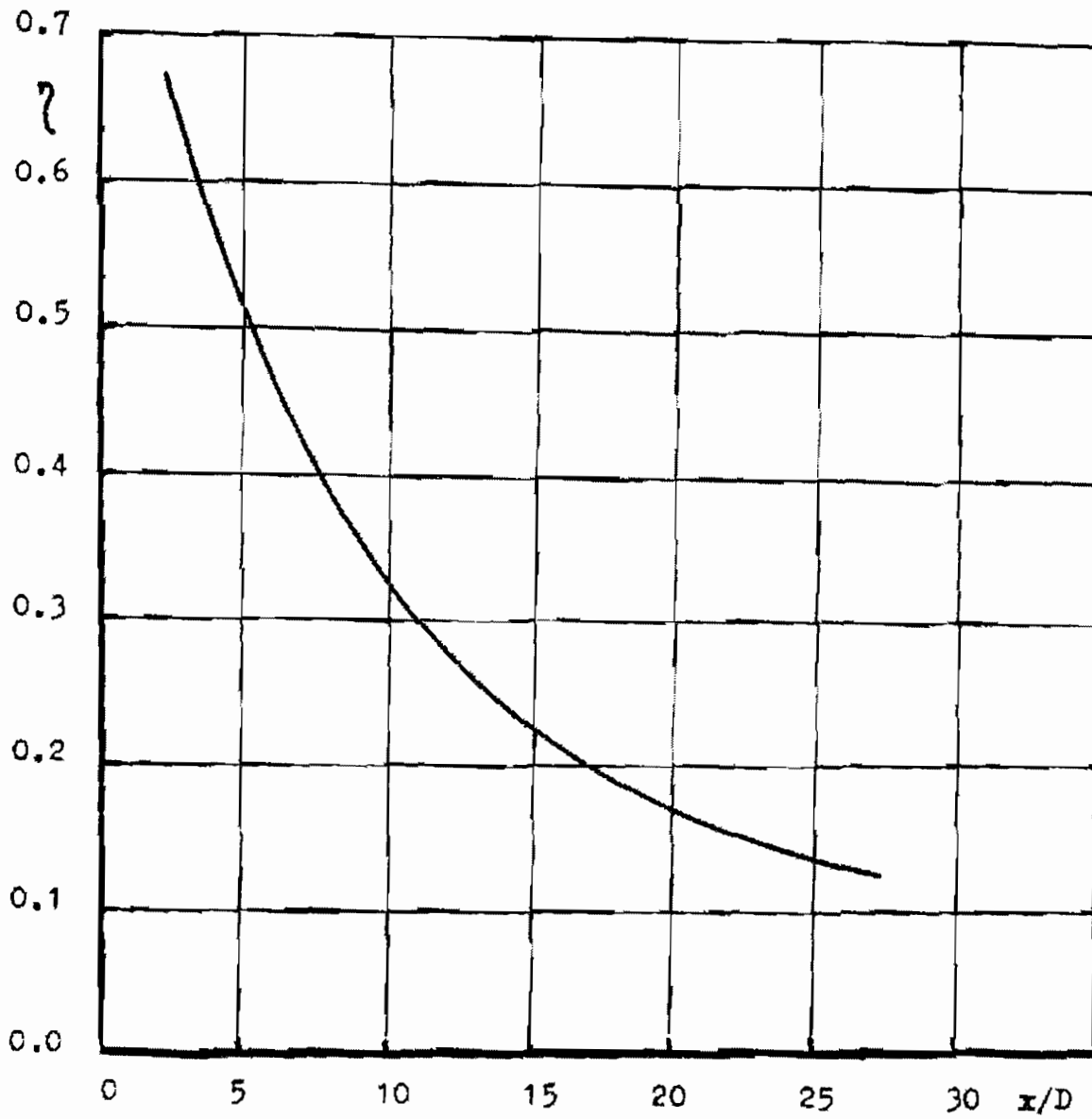

Fig. (') Film Cooling Effectiveness

